



Q



q q GQ Q



Gy

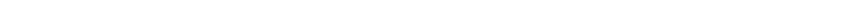

G Q

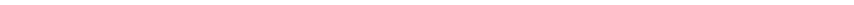

Q

G

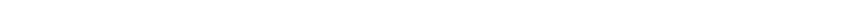

Q G G

Q



Q

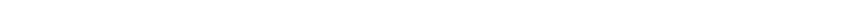

Q



Q



GQ  
 G G ffl  G

Q



Q

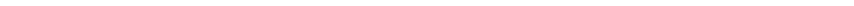
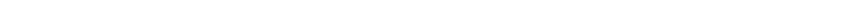

<p>G q</p>	
<p> <u>QG</u>    <u>G</u>    <u>G QG</u>                    G </p>	<p> ffl    gq    ffl            g        g            ffffl     g </p>

G

Q



G

Q





■ Q

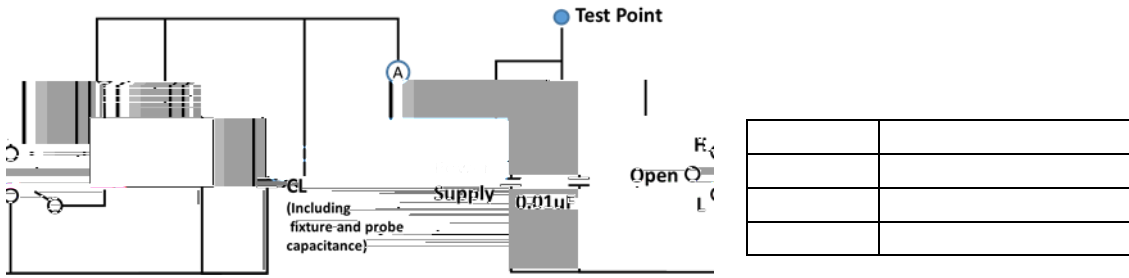

■

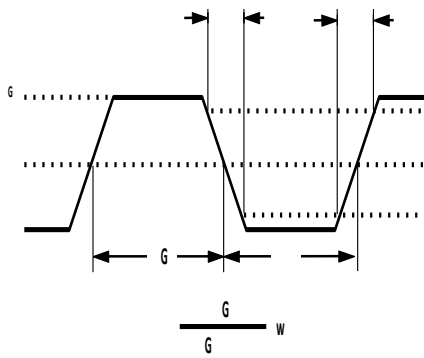

■

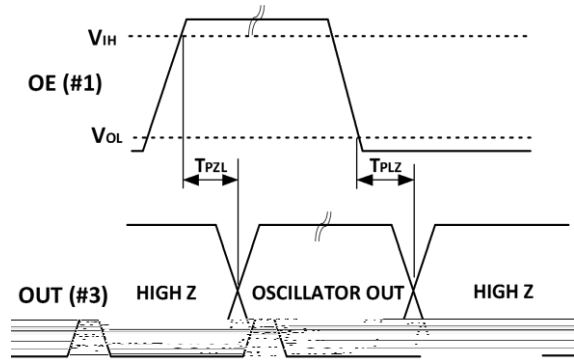

Q

**TOP VIEW**

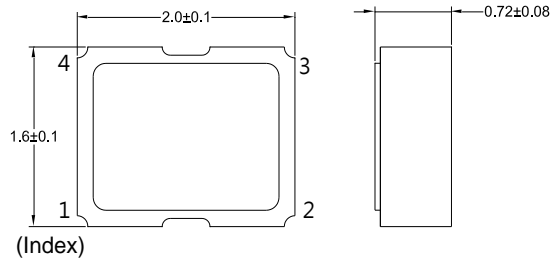

**BOTTOM VIEW**

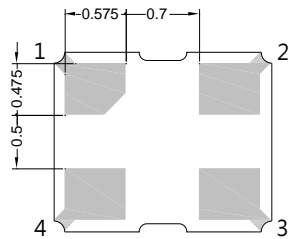

**TOP VIEW Land Pattern Layout**

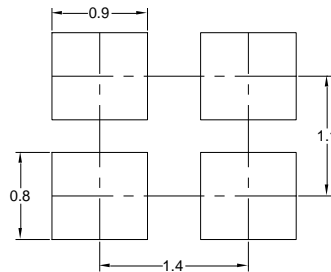

Pin Connections	
1	OE(Output Enable)
2	GND
3	Output
4	Vdd

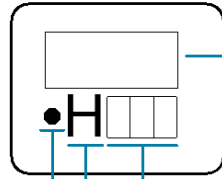

Nominal frequency  
ex. 26 MHz=>26.0

#1 Pin Location

H.E.L.E.

Date Code:YWW



Q Q

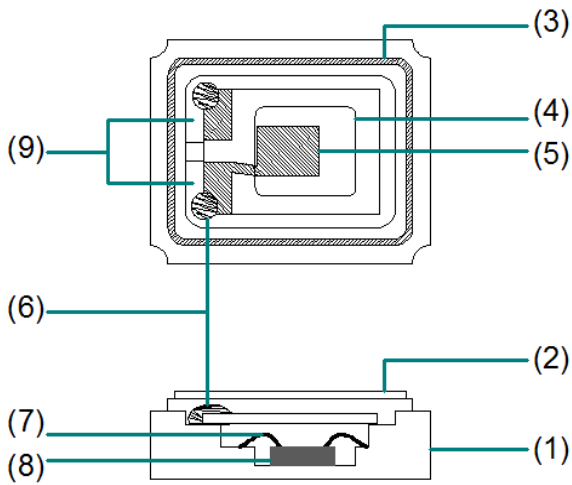

※ g q g g q q q

G q gq

G

Q Q





Q w

°C

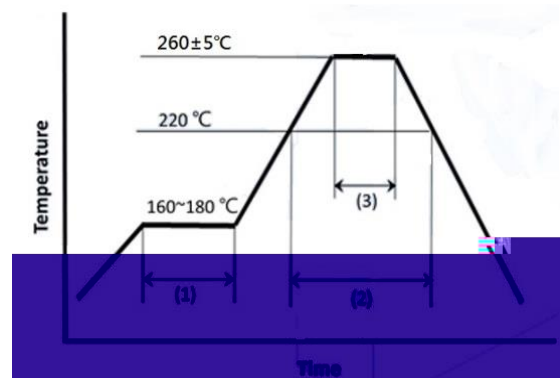

G

Q



■ ffl q

■ q ffl q

■ Q ffl q

q q ffl q q g g  
ffl q

Q

ffl q g

Q



Q



g



G

Q



■ q q fflg

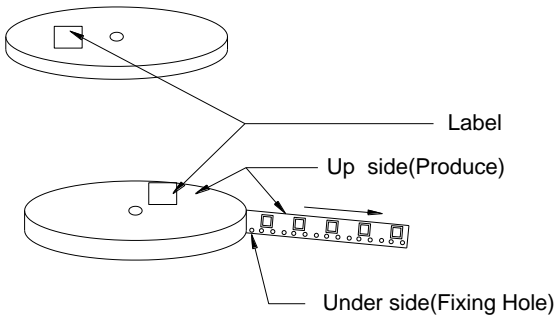
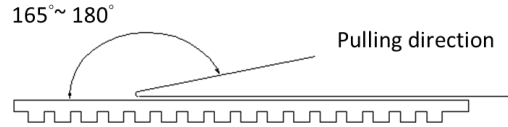

One reel quantity: [1000pcs]&[3000pcs]

- ① Top and bottom with 2.3cm thickness foam-rubber cushion for protection.
- ② Carton's Q'TY: 1~15 pcs.
- ③ Carton Type=A,B,C use 4 trigon pilla to fasten the Reel.

**Label Contents**

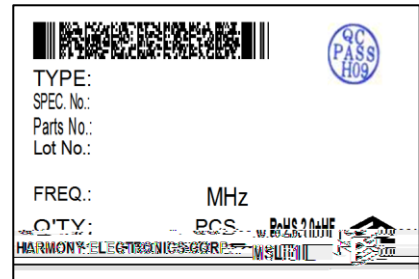

The label will be stickled on all reels.

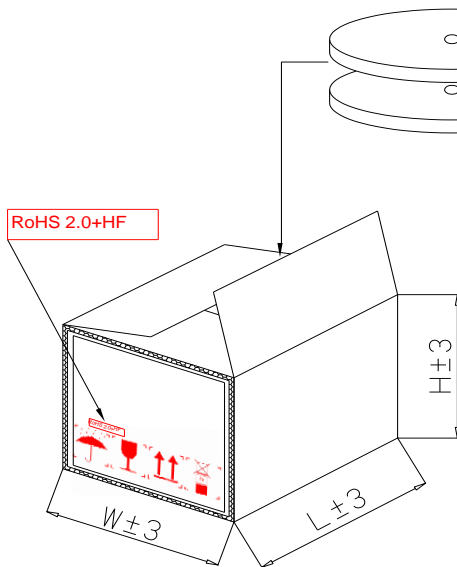
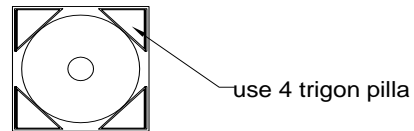

Carton Type	A	B	C	D
Produce Type	840/751	630/531/ 421	321/221 211/111	OTHER
Reel	15	15	15	1~7
L±3	200	200	200	195
W±3	200	200	200	195
H±3	230/260	230	230	150



G

		q g q	Q q
		:	
		°C	
		°C	

		q g q	Q q
		°C °C	
		°C °C	
		°C °C	
		°C °C	
		:	

G

Q

Q

G

G

G



加高電子股份有限公司  
HARMONY ELECTRONICS CORP.

